

# Model 2403/2405 Frozen Beverage Dispenser Specifications

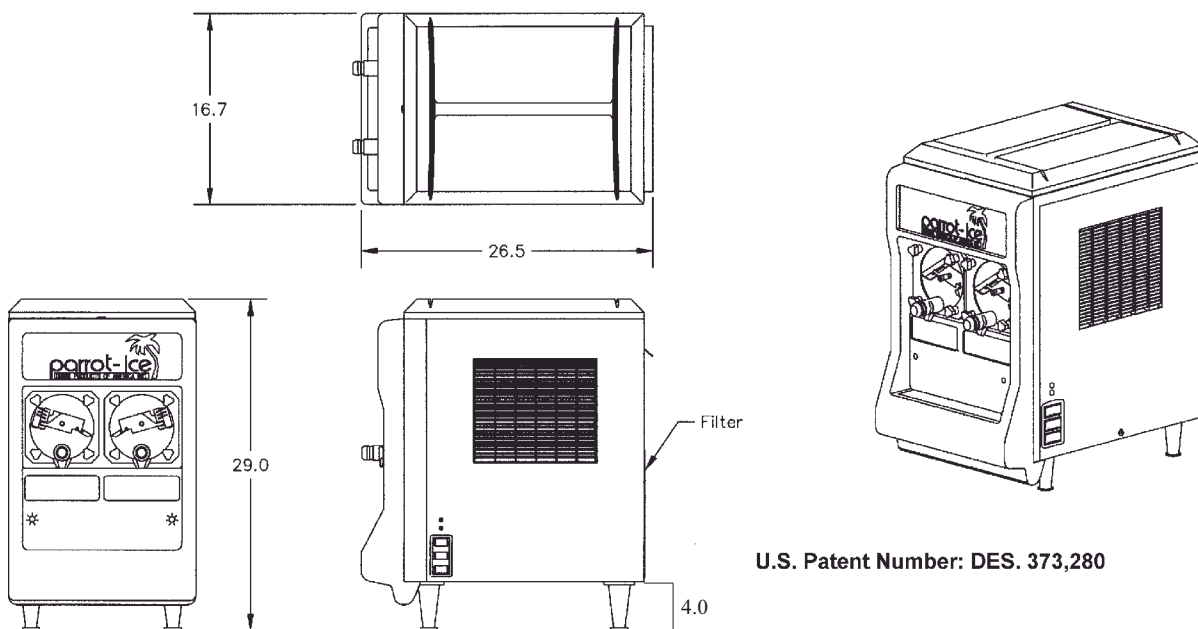

## Model

2403/2405-Dual Cylinder  
Frozen Beverage  
Counter Top Dispenser

## Compressor H.P

(2)1/3 Hp x 1300 BTU/Hr

## Refrigeration System

R134A

## Electrical Requirements

Operating Voltage 115v/20amp

Frequency - 60hz Single Phase

## Capacity

CYLINDER 3.5 QTS x 2

HOPPER 9.0 QTS. x 2

TOTAL 12.5 QTS. x 2

\* All tests performed in controlled test environment. Actual results may vary with operating conditions.

\* Due to ongoing development all specifications are subject to change without notice.

## Physical Properties

HEIGHT 29"

WIDTH 16.7"

DEPTH 26.5"

WEIGHT 185 Lbs.

COLOR Black; Stainless

CONSTRUCTION 304 Stainless; ABS Front Uniframe

## Standard Freeze Down

### Both Cylinders Loaded

60 min with product @ 75° F  
(initial time required to freeze from liquid)

## Peak Demand per Cylinder

6 servings (14 oz) x 2

(number of optimum servings which can be drawn consecutively).

## Standard Draw Rate Per Cylinder

1 Servings/2min. (14 oz) x 2

30 servings/hr (14 oz) x 2

3.25 gallons/hr x 2

(Optimum number of servings which can be drawn over specified time).

**Parrot-Ice Drink Products of America, Ltd.**