

Model 2407 Ext Frozen Beverage Dispenser Specifications

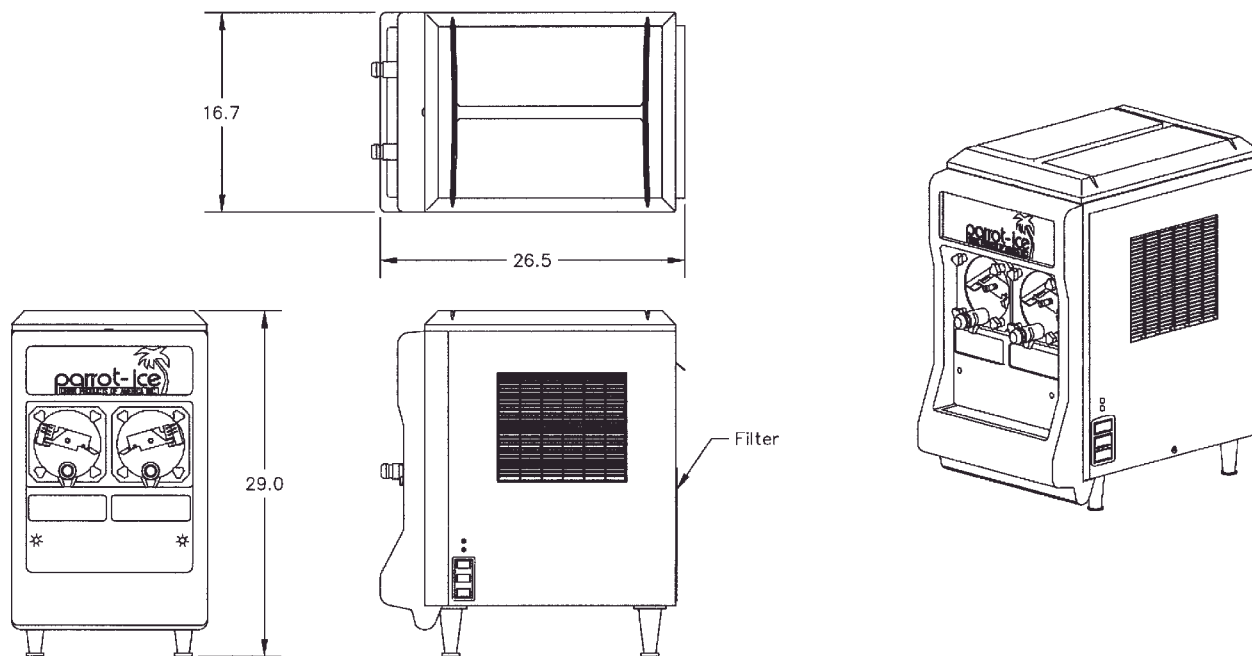

Model

2407 EXT - High Capacity,
Dual Cylinder
Frozen Beverage
Counter-Top Dispenser

Compressor H.P

(1) 0.8 Hp 6250 BTU/Hr

Refrigeration System

R404A

Electrical Requirements

Operating Voltage 115v/20amp

Frequency - 60hz Single Phase

Capacity

CYLINDER 5.0 QTS. x 2

HOPPER 9.0 QTS. x 2

TOTAL 14.0 QTS. x 2

* All tests performed in controlled test environment. Actual results may vary with operating conditions.

* Due to ongoing development all specifications are subject to change without notice.

Physical Properties

HEIGHT 29"

WIDTH 16.7"

DEPTH 26.5"

WEIGHT 175 Lbs.

COLOR Black; Stainless

CONSTRUCTION 304 Stainless; ABS Front Uniframe

Standard Freeze Down

Both Cylinders Loaded

40 min with product @ 75° F
(initial time required to freeze from liquid)

Peak Demand per Cylinder

10 servings (14 oz) x 2
(number of optimum servings which can be drawn consecutively).

Standard Draw Rate Per Cylinder

1 serving/min. (14 oz) x 2

47 servings/hr (14 oz) x 2

5.1 gallons/hr x 2

(Optimum number of servings which can be drawn over specified time).

Parrot-Ice Drink Products of America, Ltd.