

Model 303 Frozen Beverage Dispenser Specifications

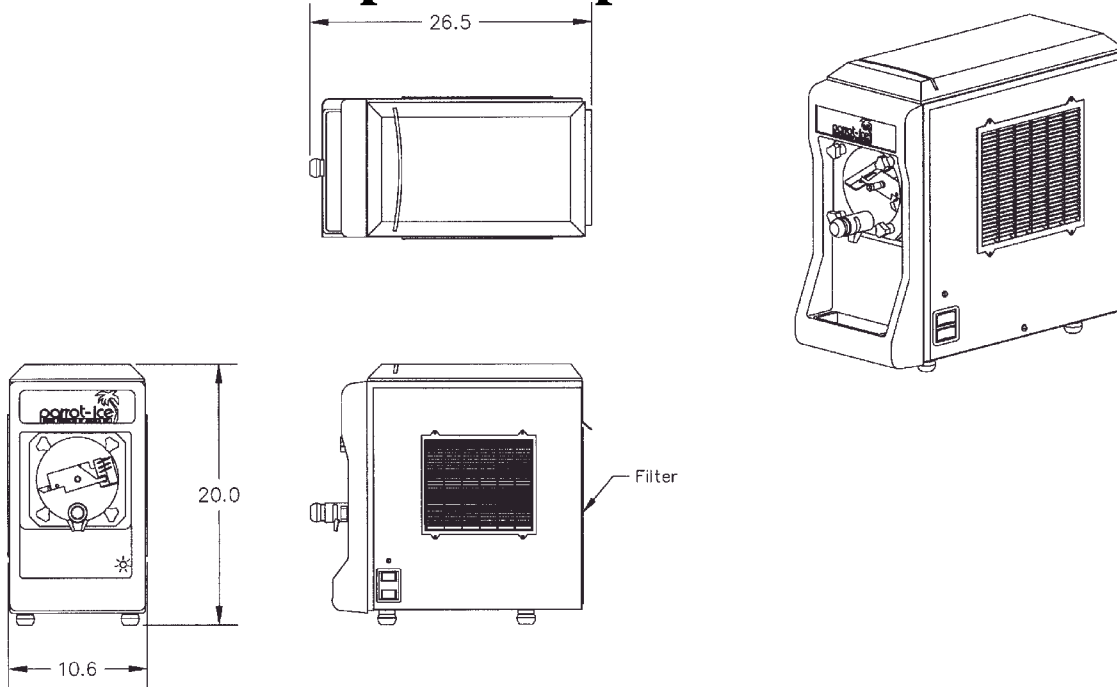

Model

303 - Single Cylinder Frozen
Beverage Counter Top
Dispenser

Compressor H.P.

(1)1/3 hp - 1300 BTU/Hr.

Refrigeration System

R-134A

Electrical Requirements

OPERATING VOLTAGE 115v/15amp

MIN. CIRCUIT

FREQUENCY - 60Hz Single Phase

Capacity

CYLINDER 3.5 QTS

HOPPER 8.0 QTS.

TOTAL 11.5 QTS.

* All tests performed in controlled
test environment. Actual results
may vary with operating conditions.

* Due to ongoing development all
specifications are subject to change
without notice.

Physical Properties

HEIGHT 20"

WIDTH 10.6"

DEPTH 26.5"

WEIGHT 118 lbs.

COLOR Stainless

CONSTRUCTION 304 Stainless; ABS Front
Uniframe

Standard Freeze Down

38 min with product @ 75°F
(initial time required to freeze
from liquid)

Peak Demand

7 servings (10 oz)
(number of optimum servings which
can be drawn consecutively)

Standard Draw Rate

1 serving every 70sec. (10 oz)
50 servings/hr (10 oz)
3.9 gallons/hr
(optimum number of servings which
can be drawn over specified time)

Parrot-Ice Drink Products of America, Ltd.